

view A:

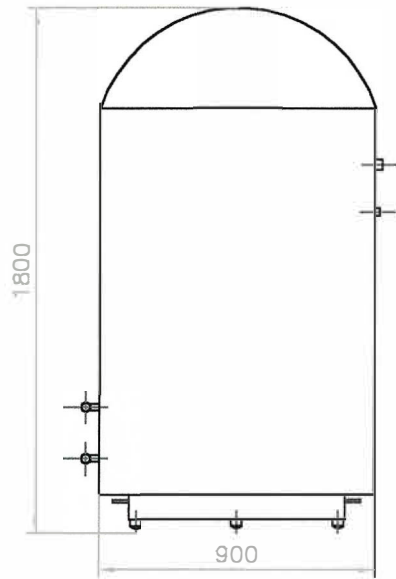

frontal view:

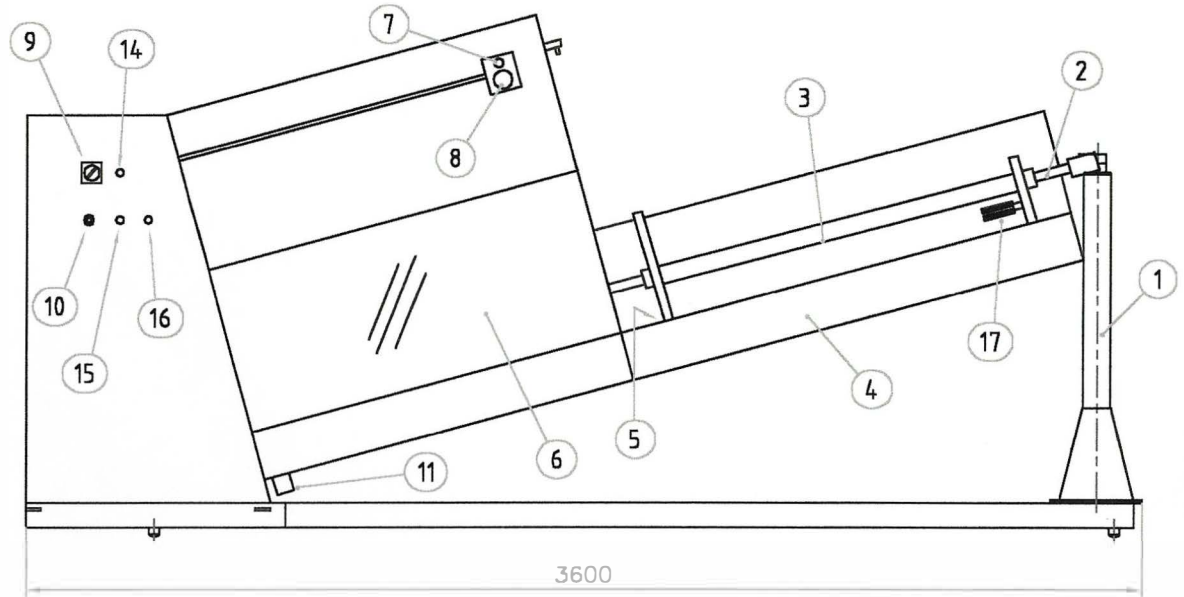

rear view:

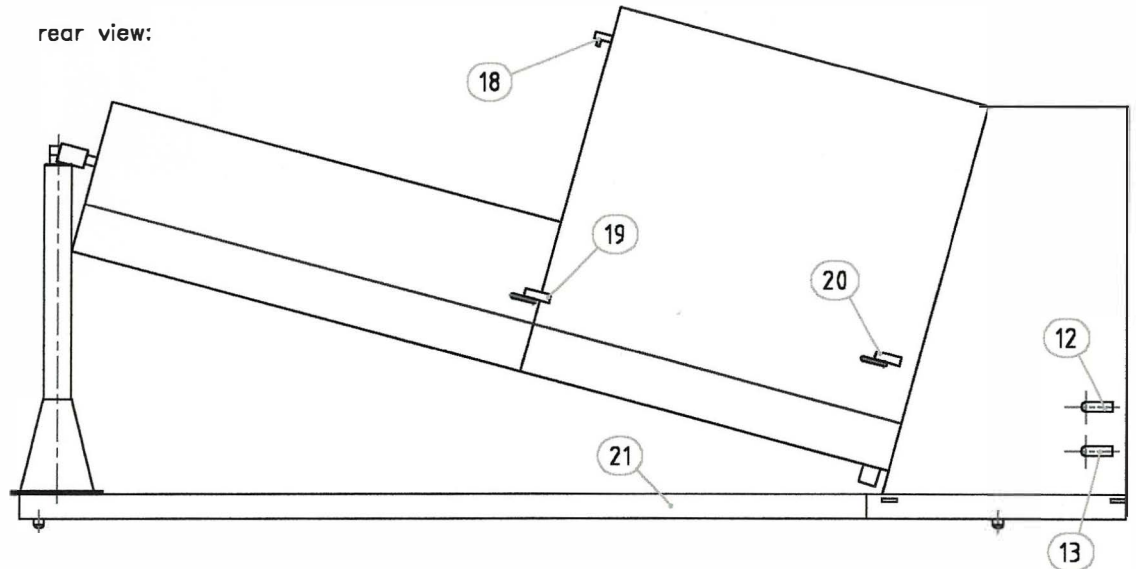

21	base	1	
20	descent limit switch	1	
19	ascent limit switch	1	
18	external drum washing for water	1	
17	bottom wash brushes	1	
16	rinsing switch ON - OFF	1	
15	washing switch ON - OFF	1	
14	start switch	1	
13	detergent solution entrance	1	
12	water entrance	1	
11	water/detergent solution free discharge	1	
10	current cable exit	1	
9	general switch	1	
8	emergency button	1	
7	start button	1	
6	rubber spray keeper	1	
5	nut position	1	
4	liquid collector	1	
3	drum-carrier truck	1	
2	guide poles	1	
1	support column	1	
Pos.	Descrizione	Qtà	Materiale

Draw name: UNIVERSAL AUTOMATIC DRUM-WASHER 2 CYCLES dimensional scheme		
Draw code: LBA_038ind	Drawer: D.G.	Date: 29/05/2001
Material: AISI 304		
Measure: mm		
Scale: 1:25		